

SECTION 4.7_KESV

EMERGENCY RELIEF VALVE PRESSURE VACUUM RELIEF

INTRODUCTION

 **The model KESV** is designed to provide emergency pressure vacuum relief for storage tanks when exposed to overpressures and overvacuum that are not handled by standard tank vents. These vents provide the capacity to meet API standard 2000 for emergency venting due to fire exposure when properly sized.

Setting Pressure

KESV Permanent Setting	Min. + 700/ - 20 mmW.C ~ Max. + 9,500/ - 700 mmW.C
------------------------	--

 **Body Materials** Aluminium, Carbon Steel, SS304 and SS316 with various trims
(Different materials available on request)

 **Sizes range** DN 400, 450, 500 and DN 600 with ASME 150Lb or API 650 flanges
(Different connections available on request)

 **Rules & Certifications** API 2000 & KFI

 **Optimum / optional Design & Arrangements** Steam jacket type, Proximity type, Teflon Coating
/Lining type

APPLICATION

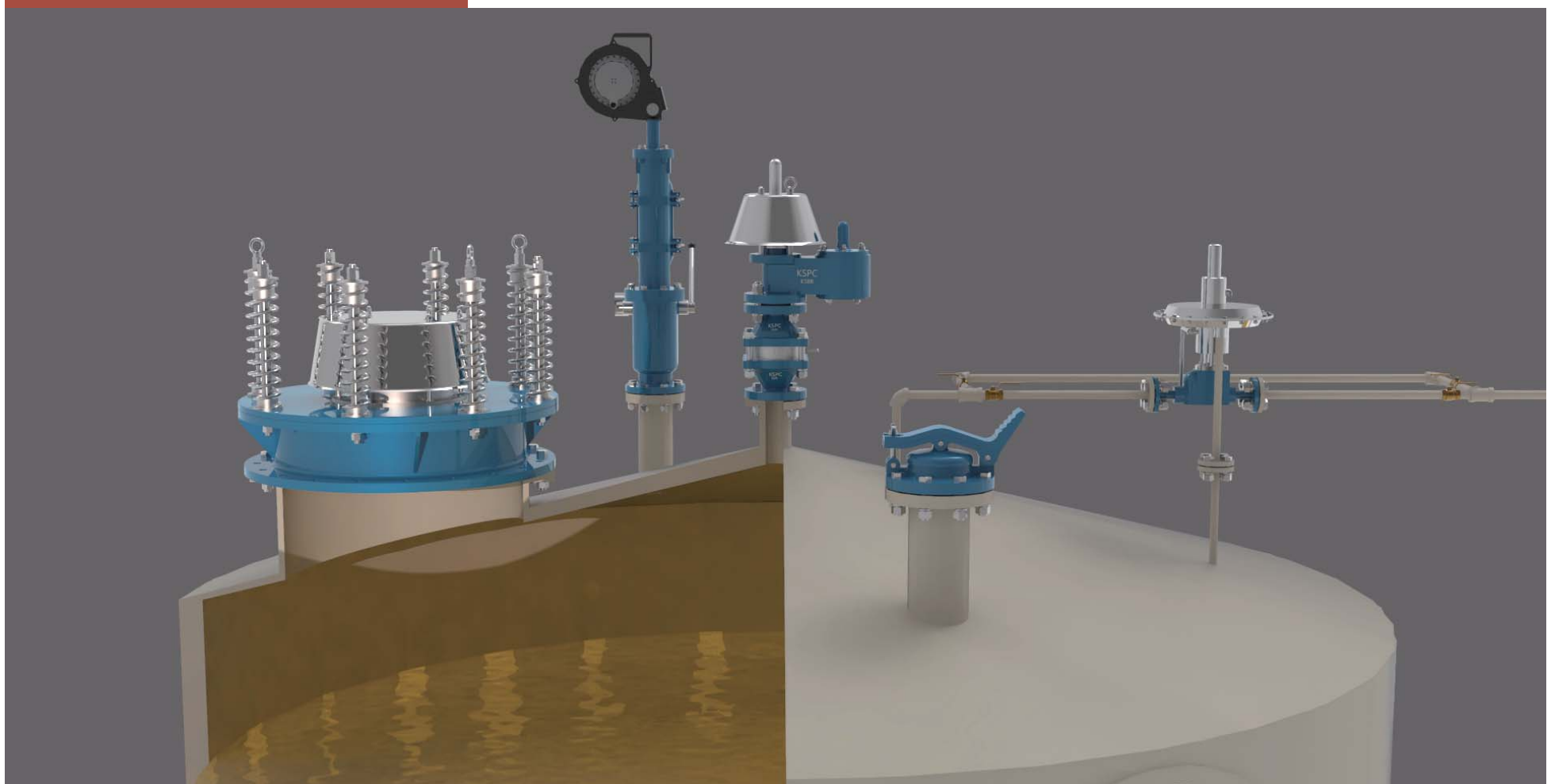

OUTLINE DRAWING

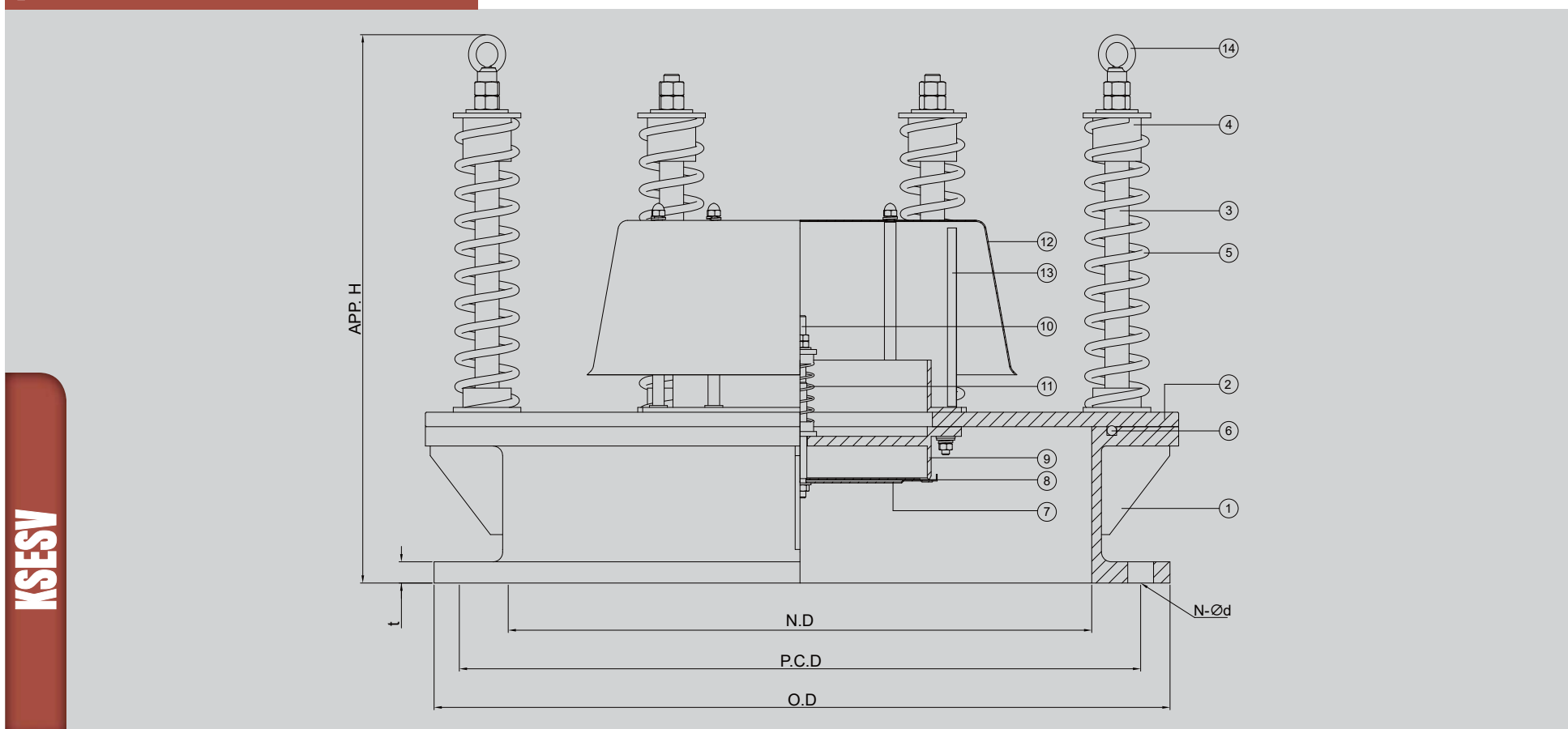

DIMENSION TABLE

SIZE		16"	18"	20"	24"
N.D		400	450	500	600
O.D	API 650	-	-	650 / 660	750 / 762
	ASME 150#	595	635	700	815
App. H	MIN.	530	530	530	530
	MAX.	590	590	590	590
P.C.D	API 650	-	-	596.9 / 590 / 597	698.5 / 690 / 699
	ASME 150#	539.7	577.8	635	749.3
N-Ød	API 650	-	-	16-Ø19 / 16-Ø20	20-Ø19 / 20-Ø20
	ASME 150#	16-Ø29	16-Ø32	20-Ø32	20-Ø35
t		18	18	18	18

NOTE Certified dimensions available upon request (STD : API650).

COMPONENT MATERIAL

ITEM NO	COMPONENT	BODY	ALUMINIUM	CARBON STEEL	SS304	SS316
		TRIM	SS304	SS304	SS304	SS316/SS316L
1	BODY	B26-319.F		A216-WCB	A351-CF8	A351-CF8M
2	PRESSURE COVER(DISC)		SS304	CARBON STEEL	SS304	SS316L
3	PRESSURE SPRING STEM		SS304	SS304	SS304	SS316
4	PRESSURE SPRING PAD		SS304	SS304	SS304	SS316
5	PRESSURE SPRING		SS304	SS304	SS304	SS316
6	O-RING	VITON (NOTE)				
7	VACUUM DISC		SS304	SS304	SS304	SS316L
8	DIAPHRAGM	FEP+PTFE (NOTE)				
9	VACUUM SEAT		SS304	SS304	SS304	SS316/SS316L
10	VACUUM SPRING STEM		SS304	SS304	SS304	SS316
11	VACUUM SPRING		SS304	SS304	SS304	SS316
12	WEATHER HOOD		SS304	SS304	SS304	SS316L
13	BIRD SCREEN		SS304	SS304	SS304	SS316
14	LIFTING EYE NUT		SS304	SS304	SS304	SS316

NOTE Other materials are available upon request.